

PC912L0NSZ Series

High Speed 25Mb/s, High CMR
DIP 8 pin *OPIC Photocoupler

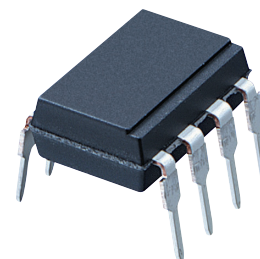

■ Description

PC912L0NSZ Series contains a LED optically coupled to an OPIC chip.

It is packaged in a 8 pin DIP, available in SMT gullwing lead-form option.

Input-output isolation voltage(rms) is 5.0 kV. Data transfer rate is MAX. 25 Mb/s and CMR is MIN. 20 kV/ μ s.

■ Features

1. DIP 8 pin package
2. Double transfer mold package
(Ideal for Flow Soldering)
3. High speed response
(t_{PHL} : MAX. 40ns, t_{PLH} : MAX. 40ns)
4. High noise immunity due to high instantaneous common mode rejection voltage
(CM_H : MIN. 20 kV/ μ s, CM_L : MIN. -20 kV/ μ s)
5. High isolation voltage between input and output
($V_{iso(rms)}$: 5.0 kV)

■ Agency approvals/Compliance

1. Recognized by UL1577 (Double protection isolation), file No. E64380 (as model No. **PC912L**)
2. Approved by TÜV (VDE0884) (as an option), file No. 87446 (as model No. **PC912L**)
3. Package resin : UL flammability grade (94V-0)

■ Applications

1. FA equipment

* "OPIC"(Optical IC) is a trademark of the SHARP Corporation. An OPIC consists of a light-detecting element and a signal-processing circuit integrated onto a single chip.

Notice The content of data sheet is subject to change without prior notice.

In the absence of confirmation by device specification sheets, SHARP takes no responsibility for any defects that may occur in equipment using any SHARP devices shown in catalogs, data books, etc. Contact SHARP in order to obtain the latest device specification sheets before using any SHARP device.

■ Internal Connection Diagram

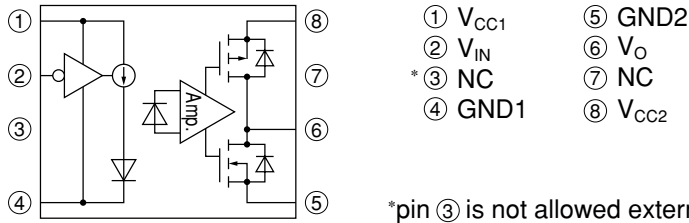

■ Truth table

Input	LED	Output
L	ON	L
H	OFF	H

L : Logic (0)

H : Logic (1)

■ Outline Dimensions

(Unit : mm)

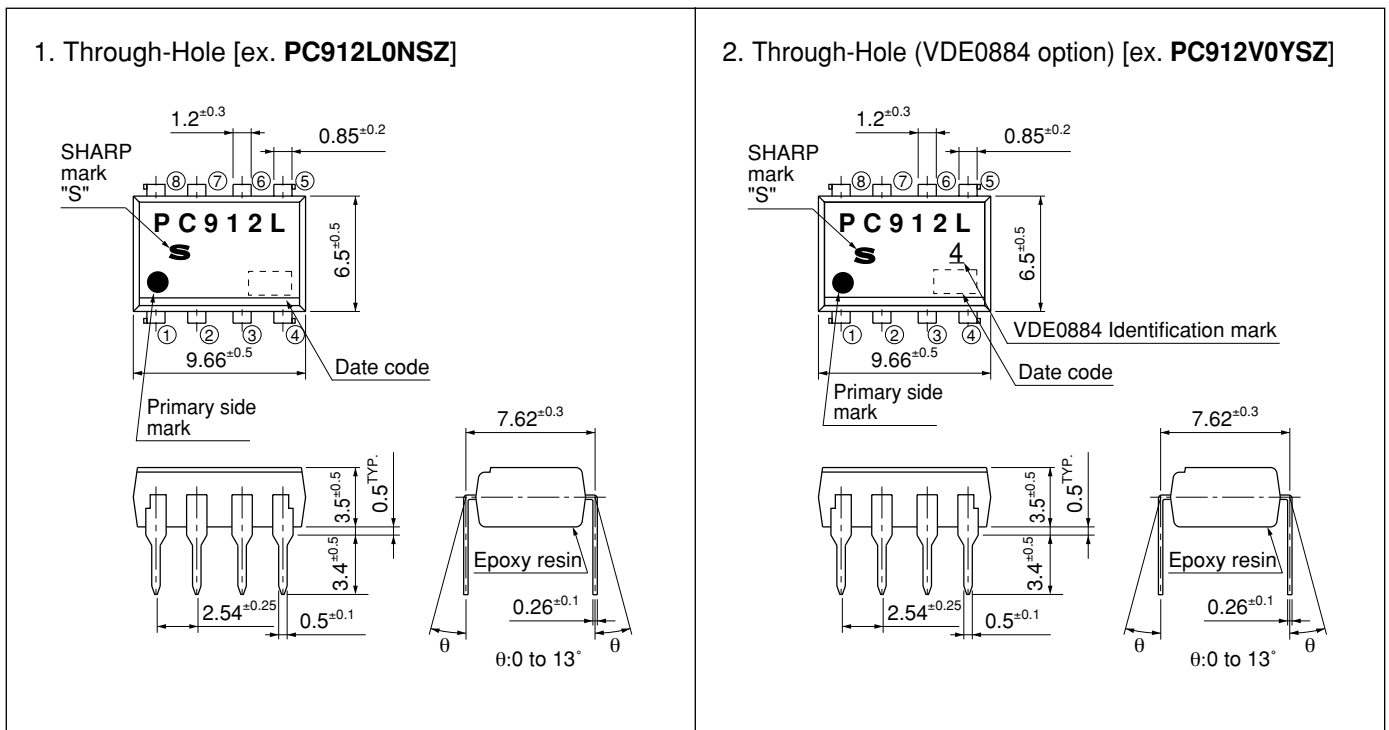

(Unit : mm)

3. SMT Gullwing Lead-Form [ex. PC912L0NIZ]

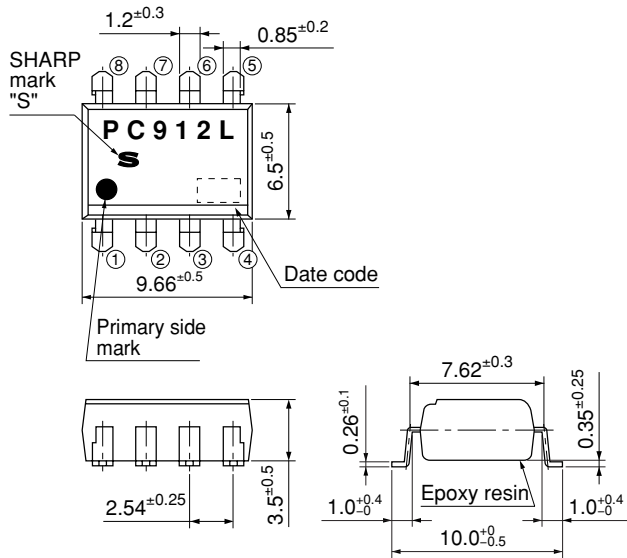

4. SMT Gullwing Lead-Form (VDE0884 option) [ex. PC912L0YIZ]

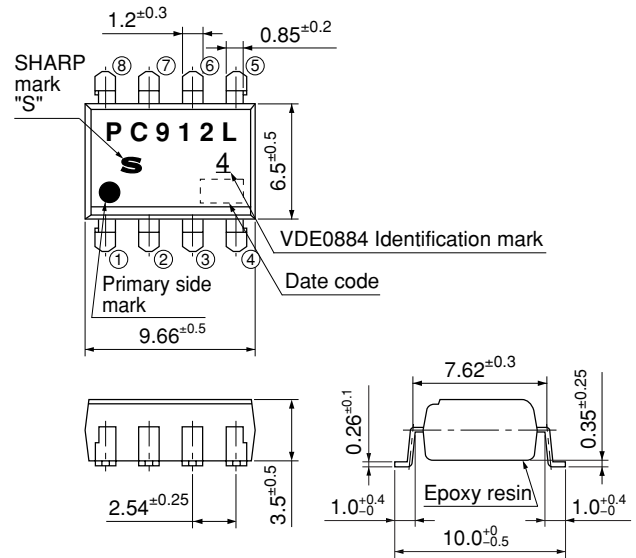

5. Wide SMT Gullwing Lead-Form [ex. PC912L0NUZ]

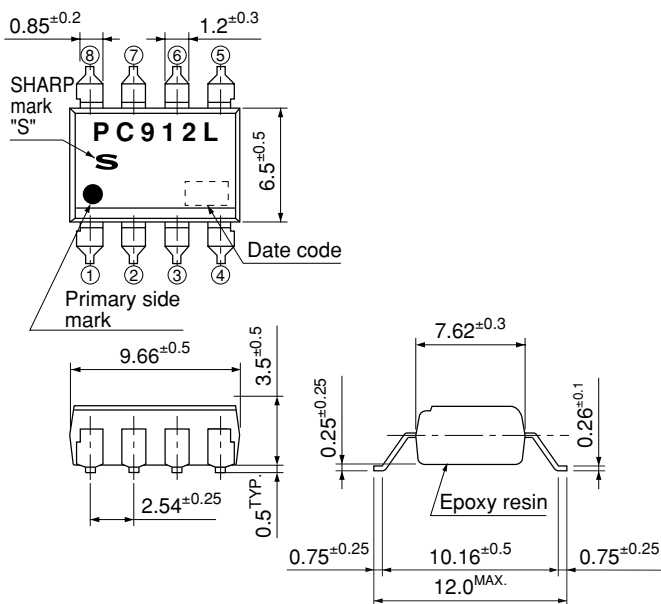

6. Wide SMT Gullwing Lead-Form (VDE0884 option) [ex. PC912L0YUZ]

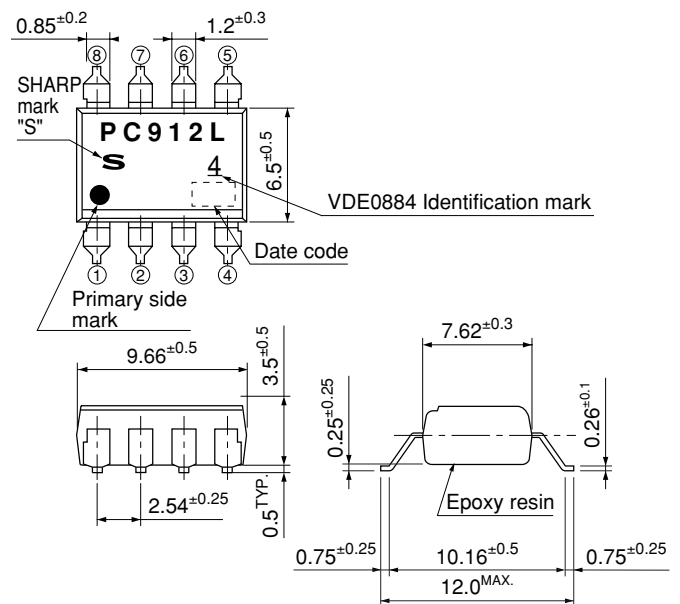

Product mass : approx. 0.49g

Date code (2 digit)

1st digit				2nd digit	
Year of production				Month of production	
A.D.	Mark	A.D	Mark	Month	Mark
1990	A	2002	P	January	1
1991	B	2003	R	February	2
1992	C	2004	S	March	3
1993	D	2005	T	April	4
1994	E	2006	U	May	5
1995	F	2007	V	June	6
1996	H	2008	W	July	7
1997	J	2009	X	August	8
1998	K	2010	A	September	9
1999	L	2011	B	October	O
2000	M	2012	C	November	N
2001	N	∴	∴	December	D

repeats in a 20 year cycle

Country of origin
Japan

■ Absolute Maximum Ratings

(Unless otherwise specified $T_a=T_{opr}$)

Parameter	Symbol	Rating	Unit	
Input	Supply voltage	V_{CC1}	0 to 5.5	V
	Input voltage	V_{IN}	-0.5 to $V_{CC1}+0.5$	V
Output	Supply voltage	V_{CC2}	0 to 5.5	V
	High level output voltage	V_O	-0.5 to $V_{CC2}+0.5$	V
	Low level output current	I_O	10	mA
*1 Isolation voltage	$V_{iso (rms)}$	5.0	kV	
Operating temperature	T_{opr}	-40 to +85	°C	
Storage temperature	T_{stg}	-55 to +125	°C	
*2 Soldering temperature	T_{sol}	270	°C	

*1 40 to 60%RH, AC for 1minute, f=60Hz

*2 For 10s

■ Electro-optical Characteristics*3

(Unless otherwise specified $T_a=T_{opr}$)

Parameter		Symbol	Conditions	MIN.	TYP.	MAX.	Unit	
Input	Low level supply current	I_{CC1L}	$V_{IN}=0V$	-	6.0	10.0	mA	
	High level supply current	I_{CC1H}	$V_{IN}=V_{CC1}$	-	0.8	3.0	mA	
	Input current	I_{IN}	$V_{CC1}=5V$	-10	-	10	μA	
Output	High level supply current	I_{CC2H}	$V_{CC1}=V_{CC2}=5V, V_{IN}=5V$	-	7.0	9.0	mA	
	Low level supply current	I_{CC2L}	$V_{CC1}=V_{CC2}=5V, V_{IN}=0V$	-	5.5	9.0	mA	
	High level output voltage	V_{OH}	$I_O=-20\mu A, V_{IN}=5V$	4.4	5.0	-	V	
			$I_O=-4mA, V_{IN}=5V$	4.0	4.8	-	V	
	Low level output voltage	V_{OL}	$I_O=20\mu A, V_{IN}=0V$	-	0	0.1	V	
			$I_O=400\mu A, V_{IN}=0V$	-	-	0.1	V	
$I_O=4mA, V_{IN}=0V$			-	0.5	1.0	V		
Isolation resistance		R_{ISO}	DC500V, 40 to 60%RH	5×10^{10}	10^{11}	-	Ω	
Transfer characteristics	Response time	"High→Low" propagation delay time	t_{PHL}	$V_{CC1}=V_{CC2}=5V$ $C_L=15pF$, CMOS Logic level $V_{IN}=0 \rightarrow 5V$ $t_r=t_f < 1ns$ Pulse width 40ns Duty 50%	-	20	40	ns
		"Low→High" propagation delay time	t_{PLH}		-	23	40	ns
		Pulse width distortion $ t_{pHL}-t_{pLH} $	Δtw		-	-	6	ns
		Propagation delay skew	T_{PSK}		-	-	20	ns
		Data transfer rate	T		-	-	25	Mb/s
		Rise time	t_r		-	9	-	ns
		Fall time	t_f		-	8	-	ns
	Instantaneous common mode rejection voltage "Output : High level"		CM_H	$V_{IN}=V_{CC1}, V_O < 0.8 \times V_{CC2}$ $V_{CM}=1kV$	20	-	-	kV/μs
	Instantaneous common mode rejection voltage "Output : Low level"		CM_L	$V_{IN}=0, V_O < 0.8V$ $V_{CM}=1kV$	-20	-	-	kV/μs

*3 When measuring output and transfer characteristics, connect a by-pass capacitor (0.01μF or more) between V_{CC1} (pin ①) and GND_1 (pin ④), between V_{CC2} (pin ⑧) and GND_2 (pin ⑤) near the device.

All typical values: at $T_a=25^\circ C, V_{CC1}=V_{CC2}=5V$

■ Model Line-up

Lead Form	Through-Hole		SMT Gullwing		Wide SMT Gullwing	
Package	Sleeve		Sleeve		Sleeve	
	50pcs/sleeve		50pcs/sleeve		50pcs/sleeve	
VDE0884	———	Approved	———	Approved	———	Approved
Model No.	PC912L0NSZ	PC912L0YSZ	PC912L0NIZ	PC912L0YIZ	PC912L0NUZ	PC912L0YUZ

Please contact a local SHARP sales representative to inquire about production status and Lead-Free options.

Fig.1 Test Circuit for Propagation Delay Time and Rise Time, Fall Time

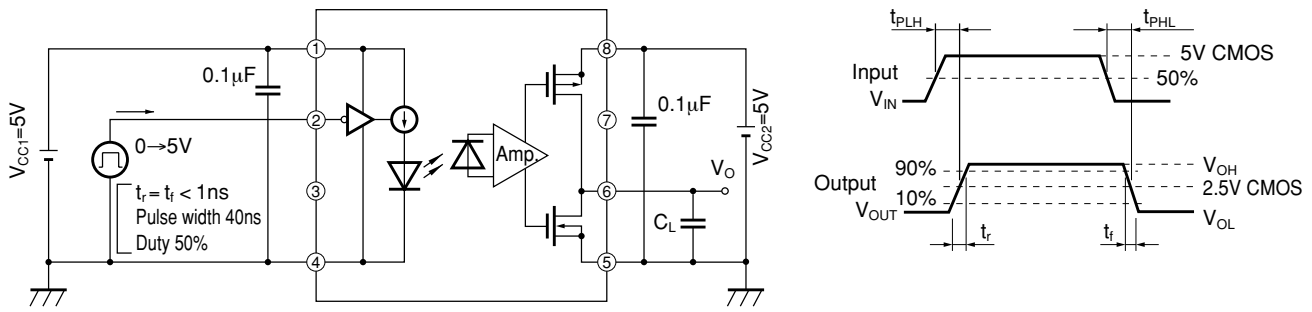

Fig.2 Test Circuit for Instantaneous Common Mode Rejection Voltage

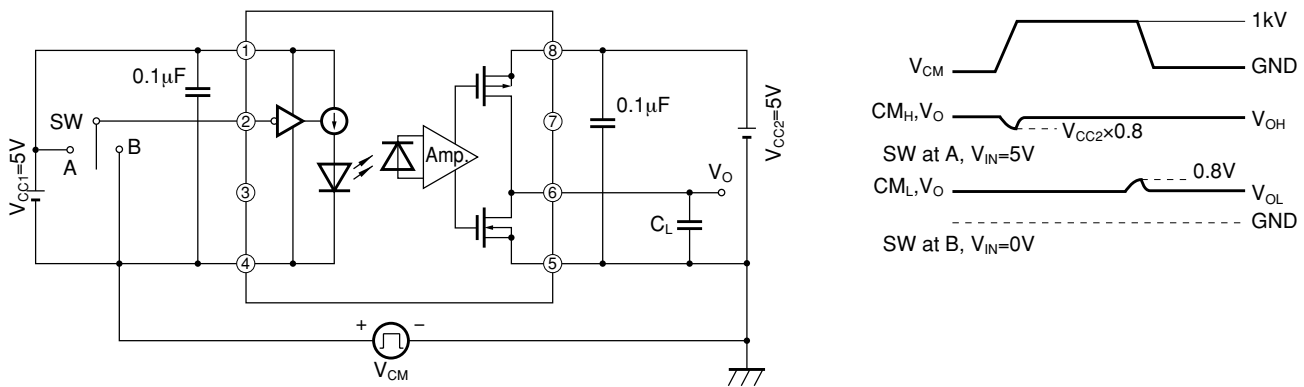

Fig.3 Propagation Delay Time vs. Ambient Temperature

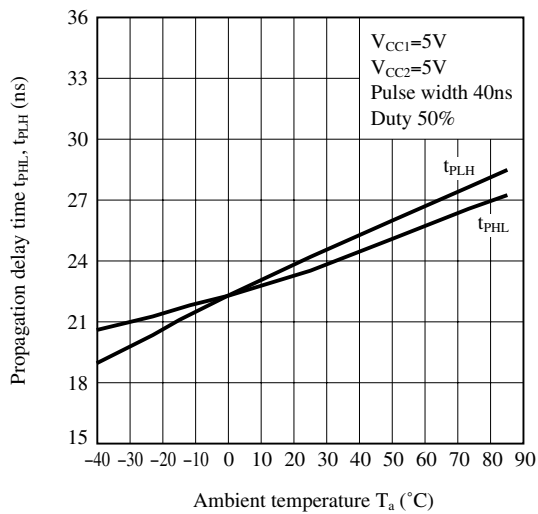

Fig.4 Pulse Width Distortion vs. Ambient Temperature

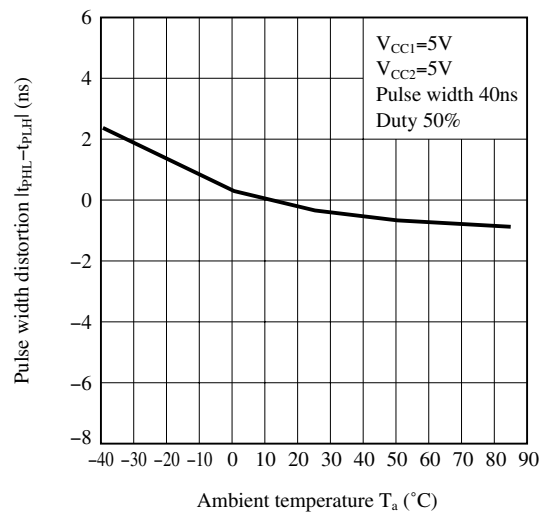
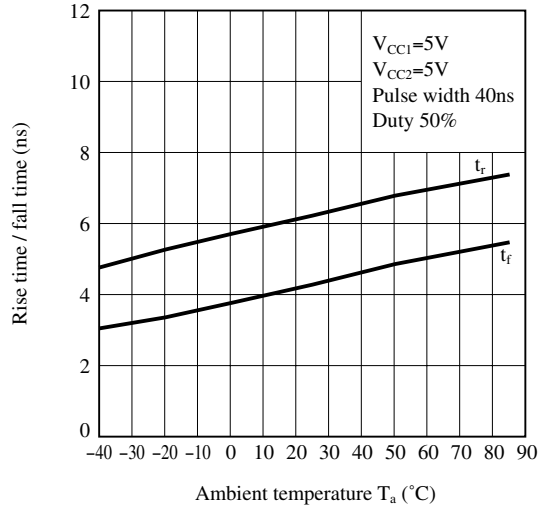

Fig.5 Rise Time / Fall Time vs. Ambient Temperature



Remarks : Please be aware that all data in the graph are just for reference and not for guarantee.

■ Design Considerations

● Recommended operating conditions

Parameter	Symbol	MIN.	TYP.	MAX.	Unit
Supply voltage	V _{CC1}	4.5	–	5.5	V
Supply voltage	V _{CC2}	4.5	–	5.5	V
Low level input voltage	V _{IL}	0	–	0.8	V
High level input voltage	V _{IH}	2.0	–	V _{CC1}	V
Operating temperature	T _{opr}	–40	–	+70	°C

● Notes about static electricity

Transistor of detector side in CMOS configuration may be damaged by static electricity due to its minute design.

When handling these devices, general countermeasure against static electricity should be taken to avoid breakdown of devices or degradation of characteristics.

● Design guide

In order to stabilize power supply line, we should certainly recommend to connect a by-pass capacitor of 0.01μF or more between V_{CC1}-GND and V_{CC2}-GND near the device.

The detector which is used in this device, has parasitic diode between each pins and GND.

There are cases that miss operation or destruction possibly may be occurred if electric potential of any pin becomes below GND level even for instant.

Therefore it shall be recommended to design the circuit that electric potential of any pin does not become below GND level.

This product is not designed against irradiation and incorporates non-coherent LED.

● Recommended Foot Print (reference)

SMT Gullwing Lead-form

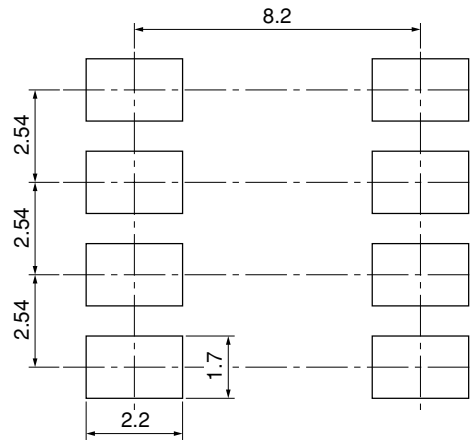

(Unit : mm)

Wide SMT Gullwing Lead-form

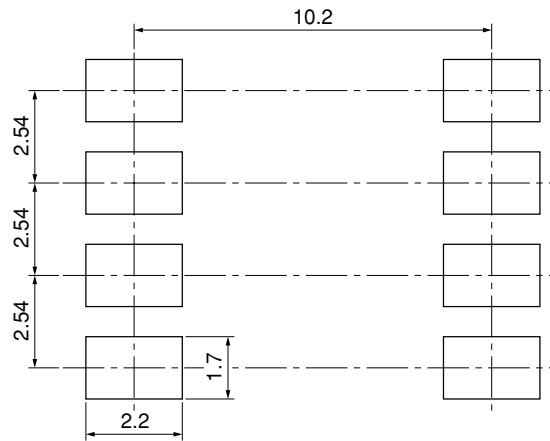

(Unit : mm)

☆ For additional design assistance, please review our corresponding Optoelectronic Application Notes.

■ Manufacturing Guidelines

● Soldering Method

Reflow Soldering:

Reflow soldering should follow the temperature profile shown below.

Soldering should not exceed the curve of temperature profile and time.

Please don't solder more than twice.

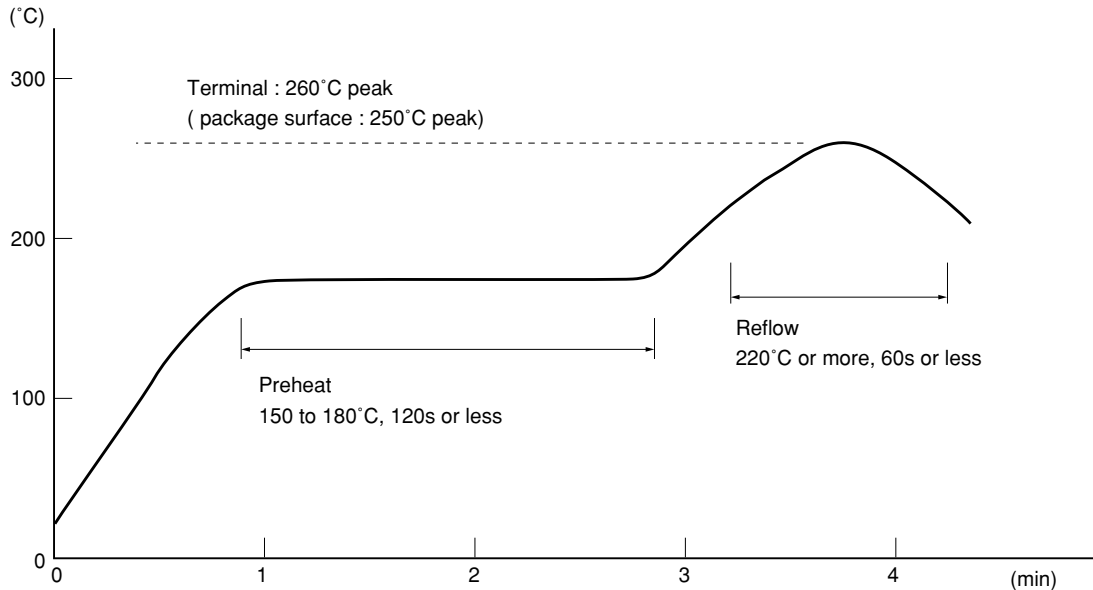

Flow Soldering :

Due to SHARP's double transfer mold construction submersion in flow solder bath is allowed under the below listed guidelines.

Flow soldering should be completed below 270°C and within 10s.

Preheating is within the bounds of 100 to 150°C and 30 to 80s.

Please don't solder more than twice.

Hand soldering

Hand soldering should be completed within 3s when the point of solder iron is below 400°C.

Please don't solder more than twice.

Other notices

Please test the soldering method in actual condition and make sure the soldering works fine, since the impact on the junction between the device and PCB varies depending on the tooling and soldering conditions.

● Cleaning instructions**Solvent cleaning:**

Solvent temperature should be 45°C or below Immersion time should be 3minutes or less

Ultrasonic cleaning:

The impact on the device varies depending on the size of the cleaning bath, ultrasonic output, cleaning time, size of PCB and mounting method of the device.

Therefore, please make sure the device withstands the ultrasonic cleaning in actual conditions in advance of mass production.

Recommended solvent materials:

Ethyl alcohol, Methyl alcohol and Isopropyl alcohol

In case the other type of solvent materials are intended to be used, please make sure they work fine in actual using conditions since some materials may erode the packaging resin.

● Presence of ODC

This product shall not contain the following materials.

And they are not used in the production process for this device.

Regulation substances : CFCs, Halon, Carbon tetrachloride, 1.1.1-Trichloroethane (Methylchloroform)

Specific brominated flame retardants such as the PBBOs and PBBs are not used in this product at all.

■ **Package specification**

● **Sleeve package**

1. Through-Hole or SMT Gullwing

Package materials

Sleeve : HIPS (with anti-static material)

Stopper : Styrene-Elastomer

Package method

MAX. 50 pcs. of products shall be packaged in a sleeve.

Both ends shall be closed by tabbed and tabless stoppers.

The product shall be arranged in the sleeve with its primary side mark on the tabless stopper side.

MAX. 20 sleeves in one case.

Sleeve outline dimensions

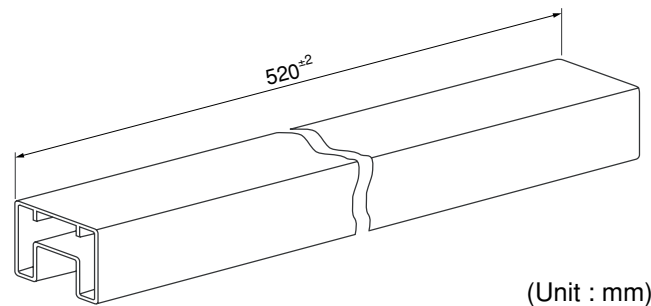
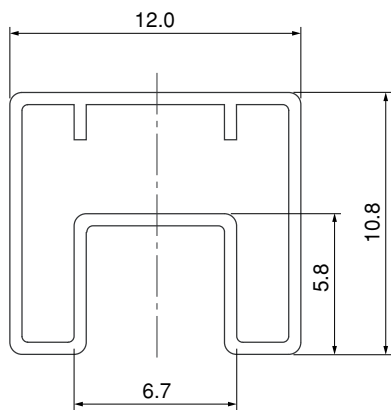

(Unit : mm)

2. Wide SMT Gullwing

Package materials

Sleeve : HIPS (with anti-static material)

Stopper : Styrene-Elastomer

Package method

MAX. 50 pcs. of products shall be packaged in a sleeve.

Both ends shall be closed by tabbed and tabless stoppers.

The product shall be arranged in the sleeve with its primary side mark on the tabless stopper side.

MAX. 20 sleeves in one case.

Sleeve outline dimensions

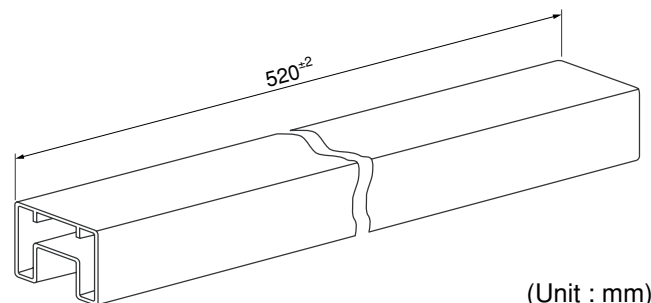
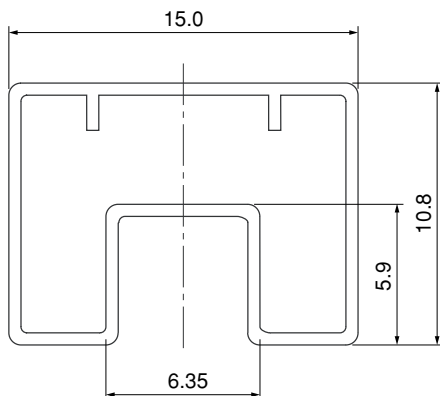

(Unit : mm)

■ Important Notices

· The circuit application examples in this publication are provided to explain representative applications of SHARP devices and are not intended to guarantee any circuit design or license any intellectual property rights. SHARP takes no responsibility for any problems related to any intellectual property right of a third party resulting from the use of SHARP's devices.

· Contact SHARP in order to obtain the latest device specification sheets before using any SHARP device. SHARP reserves the right to make changes in the specifications, characteristics, data, materials, structure, and other contents described herein at any time without notice in order to improve design or reliability. Manufacturing locations are also subject to change without notice.

· Observe the following points when using any devices in this publication. SHARP takes no responsibility for damage caused by improper use of the devices which does not meet the conditions and absolute maximum ratings to be used specified in the relevant specification sheet nor meet the following conditions:

(i) The devices in this publication are designed for use in general electronic equipment designs such as:

- Personal computers
- Office automation equipment
- Telecommunication equipment [terminal]
- Test and measurement equipment
- Industrial control
- Audio visual equipment
- Consumer electronics

(ii) Measures such as fail-safe function and redundant design should be taken to ensure reliability and safety when SHARP devices are used for or in connection

with equipment that requires higher reliability such as:

- Transportation control and safety equipment (i.e., aircraft, trains, automobiles, etc.)
- Traffic signals
- Gas leakage sensor breakers
- Alarm equipment
- Various safety devices, etc.

(iii) SHARP devices shall not be used for or in connection with equipment that requires an extremely high level of reliability and safety such as:

- Space applications
- Telecommunication equipment [trunk lines]
- Nuclear power control equipment
- Medical and other life support equipment (e.g., scuba).

· If the SHARP devices listed in this publication fall within the scope of strategic products described in the Foreign Exchange and Foreign Trade Law of Japan, it is necessary to obtain approval to export such SHARP devices.

· This publication is the proprietary product of SHARP and is copyrighted, with all rights reserved. Under the copyright laws, no part of this publication may be reproduced or transmitted in any form or by any means, electronic or mechanical, for any purpose, in whole or in part, without the express written permission of SHARP. Express written permission is also required before any use of this publication may be made by a third party.

· Contact and consult with a SHARP representative if there are any questions about the contents of this publication.